



# POLARISATION

## UNIT –III US03CPHY21

Prof. J. K. Baria



By  
Dr. Jagendra K. Baria  
Professor Of Physics  
V. P. & R. P. T. P. Science College  
Vidyanagar 388 120

# Introduction:

- Interference and diffraction phenomena proved that light is a wave motion
- These phenomena are used to find wavelength of light and they do not give any indication regarding the character of waves.
- Maxwell developed electromagnetic theory and suggested that light-waves are electromagnetic waves.
- Electromagnetic waves are transverse waves, so it is obvious that light waves are also transverse waves.
- Longitudinal waves are waves in which particles of medium oscillate along the direction of propagation of wave (e.g. sound wave).
- Transverse waves are waves in which particles of medium oscillate perpendicular to the direction of propagation of wave. (e.g. Electromagnetic waves.)
- Polarization is possible in transverse wave

# Introduction:

- **Unpolarised Light** is the light in which the planes of vibration are symmetrically distributed about the propagation direction of the wave.
- **Plane Polarized light** is a wave in which the electric vector is everywhere confined to a single plane.
- **A linearly polarized light** is a wave in which the electric vector oscillates in a given constant orientation.

# PRODUCTION OF LINEARLY POLARIZED LIGHT:

- Methods for producing Linearly polarized light :
  1. Reflection
  2. Refraction
  3. Scattering
  4. Selective absorption
  5. Double refraction.
- Applications of Polarized light:
  - ❖ Industry and Engineering fields
  - ❖ In liquid crystal displays (LCDs)
  - ❖ Widely used in wristwatches, calculators, T.V. Screens
  - ❖ Wave guides and optical fibers.

# POLARIZATION BY REFLECTION:

- In 1808, E.L.Malus discovered the polarization of natural light by reflection from the surface of glass.
- He noticed that when natural light is incident on a plane sheet of glass at a certain angle, the reflected beam is plane polarized.

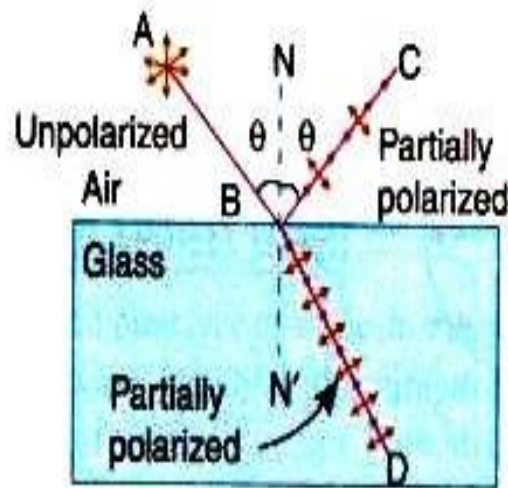

(a)

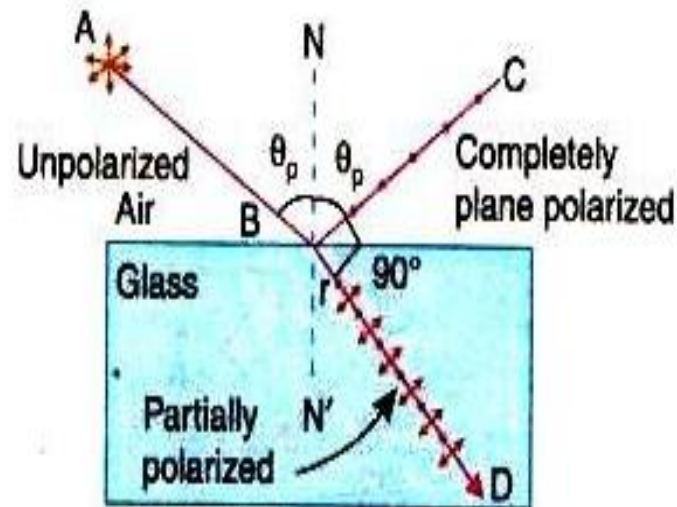

(b)

# BREWSTER'S LAW

- In 1892, Brewster performed number of experiments to study the polarization of light by reflection at the surfaces of different media.
- He found that ordinary light is completely polarized in the plane of incidence when it gets reflected from a transparent medium at a particular angle known as the 'angle of polarization.'
- He proved that *“the tangent of the angle of polarization is numerically equal to the refractive index of the medium.”*
- Also the reflected and refracted rays are perpendicular to each other.
- If  $\theta_p$  is the angle and  $\mu$  is the refractive index of the medium, then  $\mu = \tan\theta_p$
- This is known as **Brewster's law**.

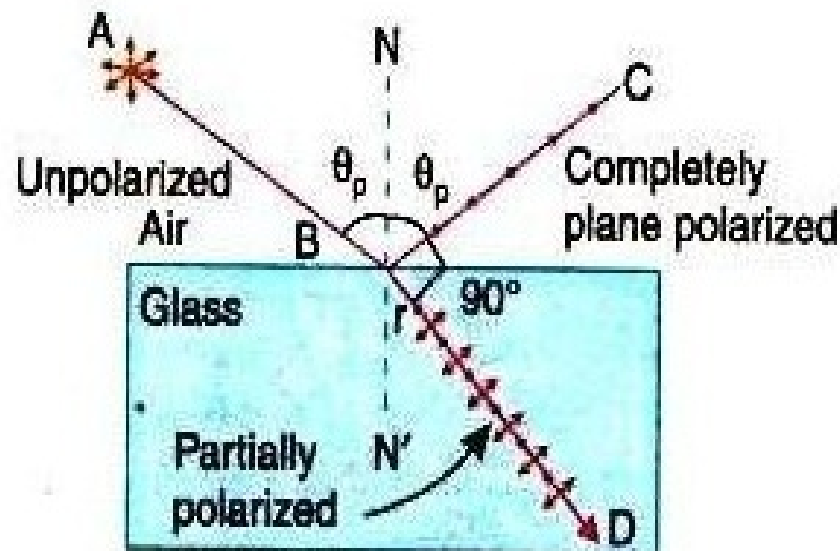

# BREWSTER'S LAW

- Brewster found that the maximum polarization of reflected ray occurs when it is at right angles to the refracted ray. It means that  $\theta_p + r = 90^\circ$
- According to Snell's law,  $\frac{\sin \theta_p}{\sin r} = \frac{\mu_2}{\mu_1}$
- Where,  $\mu_1$  is the absolute refractive index of reflecting surface, and  $\mu_2$  is the refractive index of the surrounding medium.
- $\frac{\sin \theta_p}{\sin(90^\circ - \theta_p)} = \frac{\sin \theta_p}{\cos \theta_p} = \tan \theta_p = \frac{\mu_2}{\mu_1}$
- The polarizing angle  $\theta_p$  is also known as **Brewster angle** and denoted by  $\theta_B$
- From Snell's law,  $\mu = \frac{\sin i}{\cos r}$
- From Brewster's law,  $\mu = \tan i = \frac{\sin i}{\cos i}$
- Comparing above equations,  $\cos i = \sin r = \cos\left(\frac{\pi}{2} - r\right)$
- $\left(\frac{\pi}{2} - r\right) = i \Rightarrow i + r = \frac{\pi}{2}$
- Therefore the reflected and the refracted rays are at right angles to each other.

# BREWSTER'S LAW

- From Brewster's law, the value of 'i' for crown glass of refractive index 1.52 is given by.

$$i = \tan^{-1}(1.52)$$

$$i = 56.7^\circ$$

- For ordinary glass the approximate value for the polarizing angle is  $57^\circ$ .
- For a refractive index of 1.7, the polarizing angle is  $59.5^\circ$ . Thus the polarizing angle is not widely different for different glasses.

- **Applications of Brewster's law**

1. Brewster's law can be used to determine the refractive indices of opaque materials.
2. It is used to calculate the polarizing angle for total polarization of reflected light, if refractive index of the material is known.
3. Brewster's angle can be utilized for transmitting a light beam in into or out of an optical fiber without reflections losses.



# POLARIZATION BY REFRACTION-PILE OF PLATES

- ❖ When unpolarized light is incident at Brewster's angle on a smooth glass surface, the reflected light is totally polarized while the refracted light is partially polarized.
- ❖ If natural light is transmitted through a single plate, they it is partially polarized.
- ❖ If a stack of glass plates is used instead of a single plates, reflections from successive surfaces of each glass plate filter the perpendicular component from the transmitted ray.
- ❖ The transmitted ray consists of only parallel components.

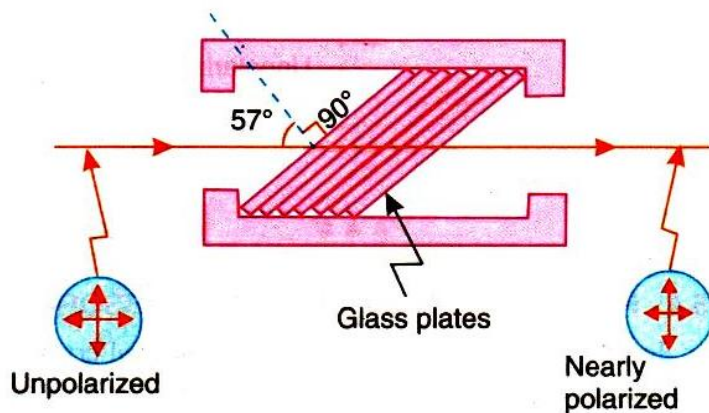

- ❖  $I_p$ - Intensity of parallel component of refracted light.
- ❖  $I_s$ - intensity of perpendicular component of light.
- ❖ Thus, degree of polarization of refracted (transmitted) light is given by

$$P = \frac{I_p - I_s}{I_p + I_s} = \frac{m}{m + \left(\frac{2\mu}{1 - \mu^2}\right)^2}$$

- ❖ where  $m$ = no. of plates required.
- ❖  $\mu$ = refractive index of material.

- ❖ About 15 glass plates are required for this purpose.
- ❖ The glass plates are kept inclined at an angle of 33° to the axis of the tube
- ❖ This arrangement is called a **pile of plates**.
- ❖ When unpolarized light is incident on the plates at Brewster angle, the transmitted light will be polarized and parallel to the plane of incidence.
- ❖ Drawback: The drawback of this method is good portion of light is lost in reflections.

# POLARIZATION BY SCATTERING

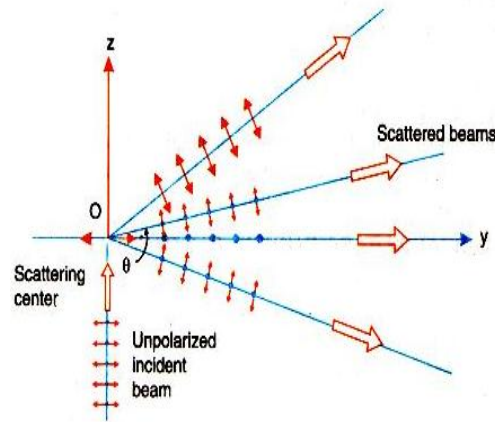

- If a narrow beam of natural light is incident on a transparent medium, contain a suspension of ultramicroscopic particles, the scattered light is partially polarized.
- The degree of polarization depends on the angle of scattering. The beam scattered at  $90^\circ$  with respect to the incident direction is linearly polarized
- Sun light scattered by air molecules is polarized.
- The maximum effect is observed on a clear day when the sun is near the horizon.
- The light reaching on the ground from directly overhead is polarized to the extent of 70% to 80%.

# POLARIZATION BY SELECTIVE ABSORPTION

- In 1815 Biot discovered that certain mineral crystal absorbs light selectively.
- When natural light passes through a crystal such as tourmaline, it splits into two components which are polarized in mutually perpendicular places.
- The crystal strongly absorbs light that is polarized in a direction parallel to a particular plane in the crystal but freely transmits the light component polarized in a perpendicular direction.
- This difference in the absorption for the rays is known as **selective absorption or dichroism**.
- The difference in absorption in different direction may be understood from the electron theory.
- When the frequency of incident light wave is close to natural frequency of the electron cloud, the light waves are absorbed strongly.
- Crystals that exhibit selective absorption are **anisotropic**.
- The crystal splits the incident wave in to two waves.
- The component having its vibration perpendicular to the principal plane of the crystal gets absorbed.
- The component with parallel vibrations is less absorbed and it is transmitted. The transmitted light is linearly polarized.
- The drawback of this method is that the crystal of bigger size cannot be grown.

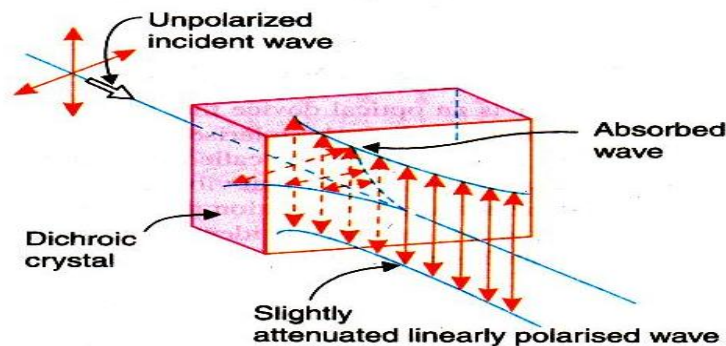

# POLARIZATION BY DOUBLE REFRACTION

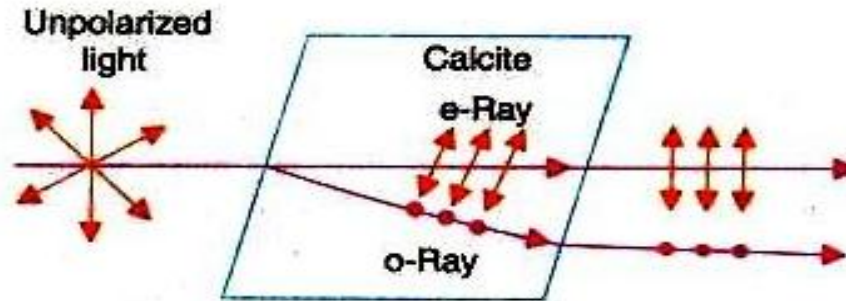

- ❖ This phenomenon was discovered by **Erasmus Bartholinus** in ~~1969~~ 1669
- ❖ When light is incident on a calcite crystal, it splits into two refracted rays.
- ❖ This phenomenon is called **double refraction** or **birefringence**. The crystal is called **birefringent**.
- ❖ The two rays produced in double refraction are linearly polarized in mutually perpendicular directions.
- ❖ The ray which obeys Snell's law of refraction is known as **ordinary ray** or **o-ray**.
- ❖ The other ray does not obey Snell's law is called **extraordinary ray** or **e-ray**.

# POLARIZER AND ANALYZER

## ➤Polarizer:-

1. It is an optical device that transforms unpolarized light into polarized light. If it produces linearly polarized light. It is called a **lineally Polarizer**.
2. If natural light is incident on a linear polarizer, only that vibration which is parallel to the transmission axis is allowed to pass through the polarizer while the vibration that is in a perpendicular direction is totally blocked.

## ➤Analyzer:-

1. Analyzer is a device, which is used to find whether the light is polarized or unpolarized.
2. Both polarizer and analyzer are fabricated in the same way and have the same effect on the incident light.

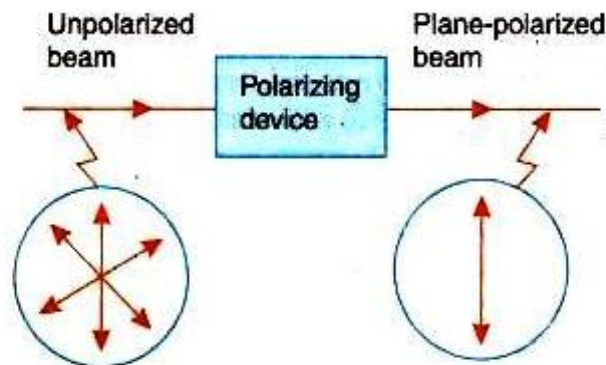

A polarizer transforms unpolarized light into polarized light.

# NICOL'S PRISM

- A Nicol prism is made from calcite crystal.
- It was designed by **William Nicol** in 1820.
- A calcite crystal whose length is three times as its width
- The end faces of this crystals are grounded in such a way that the angles in the principal section becomes  $68^\circ$  and  $112^\circ$  instead of  $71^\circ$  and  $109^\circ$
- The crystal is cut in two pieces by a plane perpendicular to the principal section as well as the new end faces.
- The two parts of the crystal are then cemented together with Canada balsam.
- The refractive index of Canada balsam lies between the refractive indices for the ordinary and extra-ordinary rays for calcite.

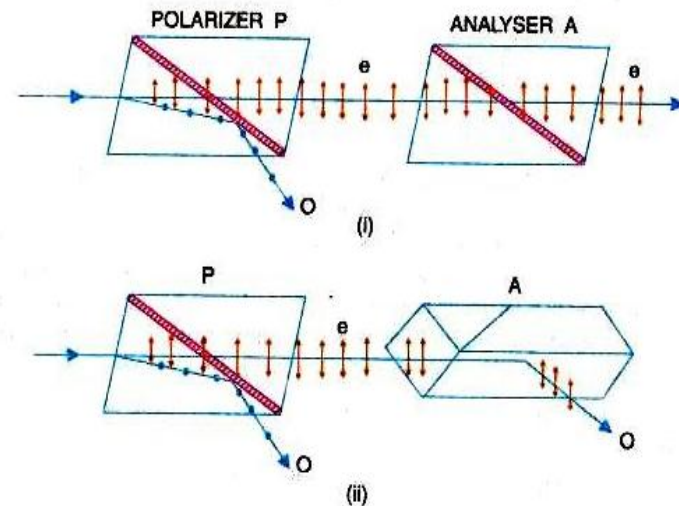
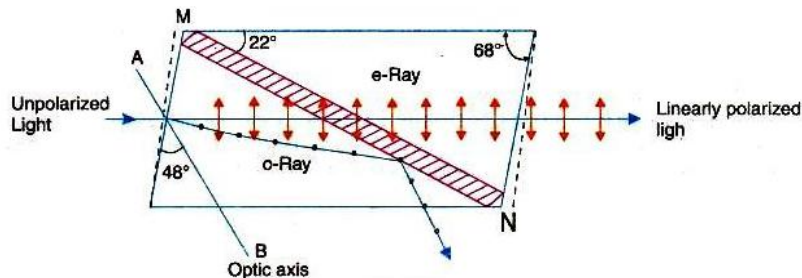

# POLAROID SHEETS

In 1928 **E.H. Laud** developed a method of aligning small crystal to obtain large polarizing sheets. The sheets are called Polaroid sheets.

## ➤ **Constructions:-**

- ❖ A clear plastic sheet of long chain molecules of polyvinyl alcohol (PVA) is heated.
- ❖ It is then stretched in a given direction to many times its original length.
- ❖ During this process, PVA molecules become aligned along the direction of stretching.
- ❖ The sheet is laminated to a rigid sheet of plastic.
- ❖ It is then exposed to iodine vapour.
- ❖ The iodine atoms attach themselves to the straight long chain of PVA molecules.
- ❖ The conduction electrons associated with iodine can move along the chains.
- ❖ A sheet fabricated according to this process is known as H-sheet.

# POLAROID SHEETS AS POLARIZER AND ANALYZER

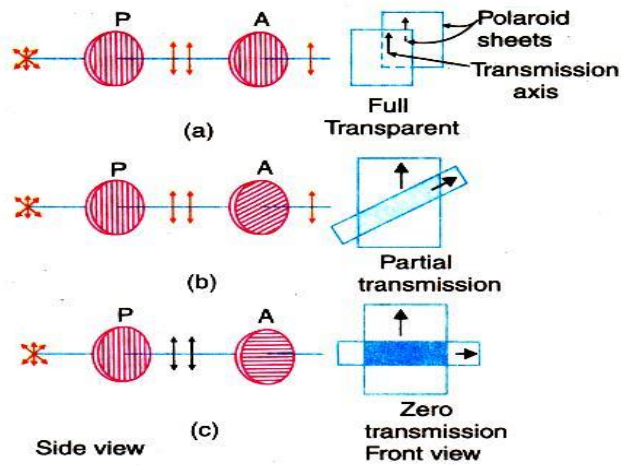

Fig (a) - transmission axis of the analyzer A is parallel to polarizer P so light passes through the analyzer.

Fig (b) Transmission axis is at angle  $\theta$  so light partially transmitted.

Fig(c) When the axes are perpendicular to each other, no light is transmitted.

## Working:

- ❖ When natural light is incident on the sheet, the component that is parallel to the chains of iodine atoms induces current in the conducting chains and is therefore strongly absorbed.
- ❖ Thus the transmitted light contains only the component that is perpendicular to the direction of molecular chains.
- ❖ The direction of E-vector in the transmitted beam corresponds to the transmission axis of the Polaroid sheet.
- ❖ These sheets are expensive and can be made in large sizes.
- ❖ They are widely used in sunglasses, camera filters etc. to eliminate the unwanted glare from objects.
- ❖ They can be used as polarizer and analyzer.



# EFFECT OF POLARIZER ON NATURAL LIGHT

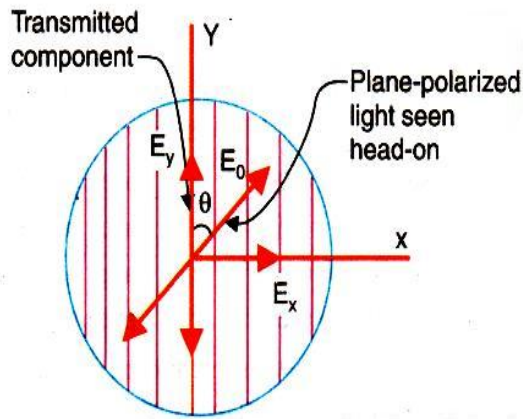

- When unpolarized light passes through a polarizer, the intensity of the transmitted light will be exactly half that of the incident light.
- Let  $E_0$  is the amplitude of vibration of the unpolarized light incident on the polarizer.
- Let  $E_0$  makes an angle  $\theta$  with the transmission axis of the polarizer.
- Here  $E_0$  may be resolved into two components  $E_x$  and  $E_y$
- The polarizer blocks the component  $E_x$  and transmits the component  $E_y$ .
- The intensity of the transmitted light

The intensity of the transmitted light is then,

$$I = E_y^2 (\cos \theta)^2 = E_0^2 (\cos^2 \theta)$$

(Only  $E_y$  component of  $E_0$  is transmitted)

But, Intensity  $\propto$  (Amplitude)<sup>2</sup>

$$\text{Therefore, } I = I_0^2 (\cos^2 \theta)$$

Now, the value  $\theta$  is from 0 to  $2\pi$  because unpolarized light has all possible vibrations.

$$I = I_0^2 \langle \cos^2 \theta \rangle = \frac{I_0}{2\pi} \times \int_0^{2\pi} \cos^2 \theta \, d\theta = \frac{I_0}{2\pi} \times \int_0^{2\pi} \frac{1 + \cos 2\theta}{2} \, d\theta$$

$$I = \frac{I_0}{4\pi} \left[ \int_0^{2\pi} d\theta + \int_0^{2\pi} \frac{1 + \cos 2\theta}{2} \, d\theta \right] = \frac{I_0}{4\pi} \left( [\theta]_0^{2\pi} + \left[ \frac{\sin 2\theta}{2} \right]_0^{2\pi} \right)$$

$$I = \frac{I_0}{4\pi} (2\pi + 0) = \frac{I_0}{2}$$

Thus, the intensity of transmitted light through the polarizer is half the intensity of incident light.

# EFFECT OF ANALYZER ON PLANE POLARIZED LIGHT- MALUS LAW

When natural light is incident on a polarizer, the transmitted light is linearly polarized. If this light-further passes through an analyzer, the intensity varies with the angle between the transmissions axes of polarizer, and analyzer.

Malus studied their phenomenon and known as Malus law.

Statement: *"The intensity of the polarized light transmitted through the analyzer is proportional to cosine square of the angle between the plane of transmission of the analyzer and plane of transmission of the polarizer."*

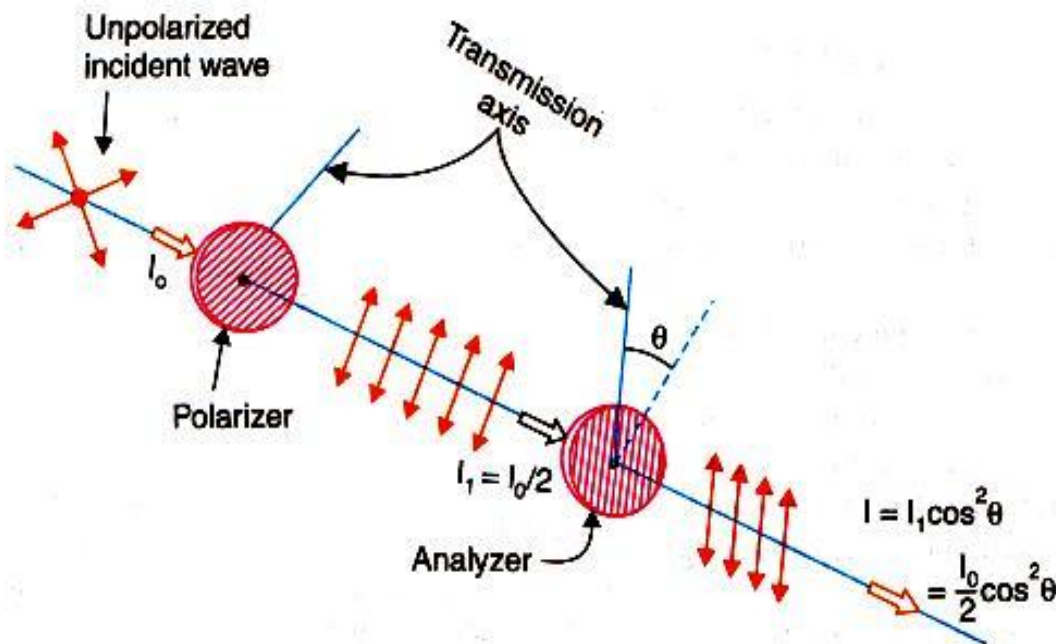

# EFFECT OF ANALYZER ON PLANE POLARIZED LIGHT- MALUS LAW

Let  $I_0$  is the intensity of unpolarized light. The intensity of polarized light from the polarizer is  $I_0/2$ .  
Take  $I_1=I_0/2$ .

This plane polarized light then passes through the analyzer. Let  $E$  is the aptitude of vibration and  $Q$  is the angle between this vibration and transmission axis of an analyzer.  $E$  resolves into two components (i)  $E_y$  parallel to the plane of transmission of the plane of analyzer and (ii)  $E_x$ , perpendicular to the plane of analyzer.

Now,  $E_y$  component is only transmitted through the analyzer.  $E_y = E \cos \theta$

Intensity of light for this component:  $I = E^2 \cos^2 \theta = I_1 \cos^2 \theta = \left(\frac{I_0}{2}\right) \cos^2 \theta$

If,

- (i)  $\theta = 0^\circ$ , then axis are parallel  $I= I_1$
- (ii)  $\theta = 90^\circ$ , then axis are perpendicular  $I= 0$
- (iii)  $\theta = 180^\circ$ , then axis are parallel  $I= I_1$
- (iv)  $\theta = 270^\circ$ , then axis are perpendicular  $I= 0$

Thus, there are two positions of maximum intensity and two positions of zero intensity when we rotate the axis of the analyzer with respect to that of the polarizer.

# Anisotropic Crystals

## Isotropic Materials:-

In isotropic materials atoms are arranged in a regular periodic manner. In isotropic materials, when a light beam is incident, it refracts a single ray. It means that in such material the refractive index is same in all direction. e. g. Glass water and air

## Anisotropic Materials:-

In anisotropic material the arrangement of atoms differs in different directions within a crystal. Thus the physical properties vary like, thermal conductivity, electrical conductivity, velocity of light and have refractive index etc. vary with the directions. Such crystal are then said Anisotropic.

The anisotropic crystals are divided into two classes.

(i) **Uniaxial Crystal:** In this type of crystal, one of the refracted rays is on ordinary ray and the other is an extraordinary. e. g. Calcite, tourmaline and Quartz.

(ii) **Biaxial Crystal:** In biaxial crystal both the refracted rays are extra ordinary rays. e. g. mica, topaz & aragonite.

# Calcite Crystal

Calcite crystal is the form of a rhombohedron bounded by six parallelograms with angles equal to  $78^\circ$  and  $102^\circ$ .

At two opposite corners (A&H) the three angles of faces meeting there are all obtuse (larger than  $90^\circ$ )

These corners (A&H) are known as blunt corners.

## ➤ Optic axis

A line passing through 'A' making equal angles with each of the three corners gives the direction of optic axis. Any line parallel to this line is also an optic axis.

AH is the optic axis of calcite crystal.

If a ray of light is incident along the optic axis or in a direction parallel to the optic axis, then it will not split up into two rays.

Thus the phenomenon of double refraction is absent when the light is allowed to enter the crystal along the optic axis.

## Principal Section :

A plane containing the optic axis and perpendicular to a pair of opposite faces of the crystal is called the principal section of the crystal for that pair of faces.

As a crystal has six faces, so far every point inside the crystal there are three principal sections, one for each pair of opposite crystal faces.

A principal section cuts the crystal surfaces in a parallelogram having angles  $71^\circ$  and  $109^\circ$

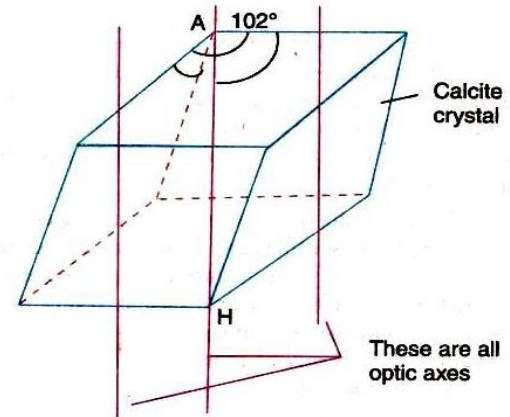

# Calcite Crystal

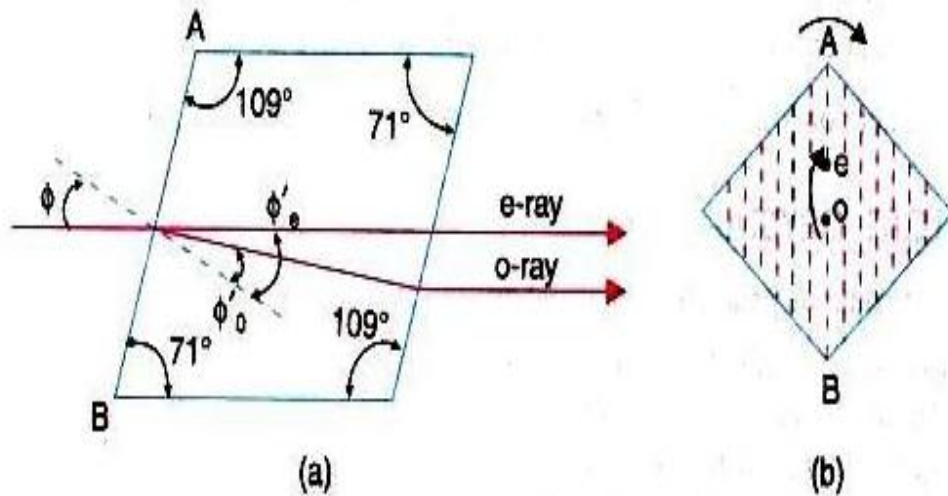

In fig(a) the principal section of the crystal is shown.

An end view of any principal section is a straight line (shown by dotted line in fig(b))

The plane containing the optical axis and the O -ray is called the principal plane of O -ray.

The plane containing the optic axis and the E-ray is called the principal plane of E-ray.

# Double refraction

When a ray of light is refracted by a crystal of calcite it gives two refracted rays. This phenomenon is called "**DOUBLE REFRACTION**".

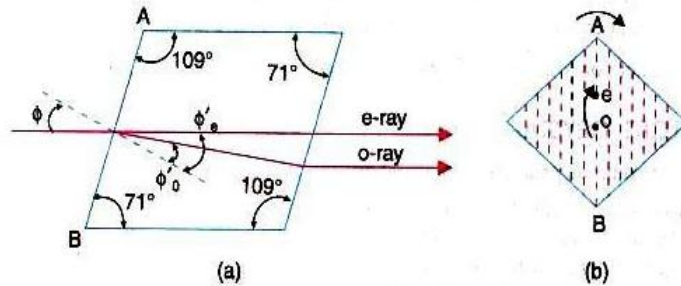

## ➤ Positive crystal:

When refractive index for extraordinary ray is greater than that of O-ray  $\mu_e > \mu_o$ .

## ➤ Negative crystal:

when refractive index for extraordinary ray is lesser than that of O-ray  $\mu_e < \mu_o$

Mark an ink dot on a piece of paper.

If we place a calcite crystal over this dot, then two images of dots are observed.

Now rotate the crystal slowly as shown in figure ii.

It is found that one image remains stationary and the second image rotates with the rotation of the crystal.

The stationary image is known as the ordinary image

The second image is known as the extraordinary image.

The refracted ray which produces ordinary image is known as **ordinary ray O-ray**

The refracted ray which produces extraordinary image is known **extraordinary ray (E-ray)**.

## Double refraction

When a ray of light AB is incident in the calcite crystal making an angle of incidence  $i$ , it is refracted along two paths inside the crystal

- (i) Along BC making our angle of retraction  $r_2$  and
- (ii) Along BD making our angle of refraction  $r_1$ .

These two rays emerge out along CE and DO are parallel.

**The difference between o-ray and e-ray is given below:**

- 1) The ordinary ray has a refractive index  $\mu_0 = \frac{\sin i}{\sin r_1}$  and the extraordinary ray has a refractive index  $\mu_e = \frac{\sin i}{\sin r_2}$ .
- 2) The O-ray obeys the laws of refraction and its refractive index is constant. For E-ray its refractive index varies with the angle of incidence and it is not fixed.
- 3) For the case of calcite  $\mu_0 > \mu_e$  because  $r_1$  less than  $r_2$ . Therefore, the velocity of light for the O-ray inside the crystal is less than the velocity of light for E-ray. ( $\mu_0 = \frac{c}{v_0}$  and  $\mu_e = \frac{c}{v_e}$ ).
- 4) The O-ray travels in the crystal with same velocity in all directions; where as the velocity of E-ray is different in different directions, because its refractive index varies.
- 5) Both O-ray and E-ray is plane polarized and they are polarized in mutually perpendicular planes.



# Huygens' explanation of double refraction in uniaxial crystal

According to Huygens, the each point on a wave front acts as a fresh source of secondary wavelets.

He explained the phenomena of double refraction in uniaxial crystal with the help of secondary wavelets.

Theory:

1. When any wave front strikes a doubly refraction crystal, every point of the crystal becomes a source of two wavefronts.
2. Ordinary wavefront corresponding to ordinary rays.
3. Since ordinary rays have same velocity in all directions, the secondary wave front is spherical.
4. Extra-ordinary wavefront corresponding to extra-ordinary rays.
5. Since extra-ordinary rays have different velocities in different directions,
6. The extra-ordinary wave front is ellipsoid with optic axis as the axis of revolution.
7. The sphere and ellipsoid touch each other at points which lie on the optic axis of the crystal, because two velocity of ordinary and extra ordinary ray is same along the optic axis.
8. In certain crystals like calcite and tourmaline called the negative crystal
9. The ellipsoid lies outside the sphere as shown in fig.(a).

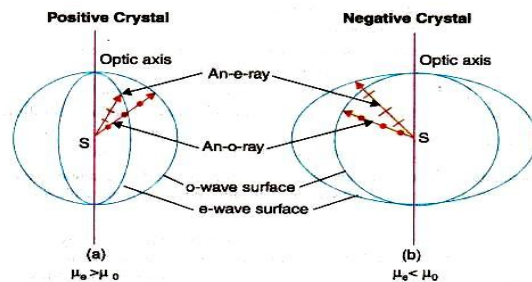

Huygens wave surfaces produced by a point source  $S$  embedded in the birefringent crystal; (a) a positive crystal (b) a negative crystal.

10. In negative crystals, the extra-ordinary wavefront travels faster than ordinary wavefront except along optic axis.
11. ( $v_e > v_o$  and  $\mu_o > \mu_e$ ).
12. In certain crystal (like quartz). Sphere lies outside the ellipsoid as shown in fig-b.
13. Such crystals are called positive crystals.
14. In the crystals, velocity of ordinary wavefront is greater than extraordinary wave front except along optic axis.

# Positive Crystal and Negative Crystal

Positive Crystal		Negative Crystal	
1.	In positive crystals the refractive index for e-ray is greater than refractive index for o-ray i.e. $\mu_e > \mu_o$ .	1.	In negative crystals the refractive index for o-ray is greater than refractive index for e-ray i.e. $\mu_o > \mu_e$
2.	In positive crystals e-ray travels slower than o-ray in all directions except along the optic axis. $V_o > V_e$	2.	In negative crystals o-ray travels slower than e-ray in all directions except along the optic axis i.e. $V_o < V_e$
3.	According to Huygen's ellipse corresponding to e-ray is contained within the sphere corresponding to o-ray	3.	According to Huygen's ellipse corresponding to e-ray lies outside the sphere corresponding to o-ray
4.	Birefringence or amount of double refraction of a crystal is defined as $\Delta\mu = \mu_e - \mu_o$ and $\Delta\mu$ is positive quantity for positive crystals	4.	$\Delta\mu$ is negative for negative crystals.
5.	Example: Quartz	5.	Example: calcite

# Superposition of waves linearly polarized at right angles

Let consider two light waves travelling in the x-direction one wave is polarized in x-y plane and the other is polarized y-z plane. Let us find effect produced because of the super positions of these two waves.

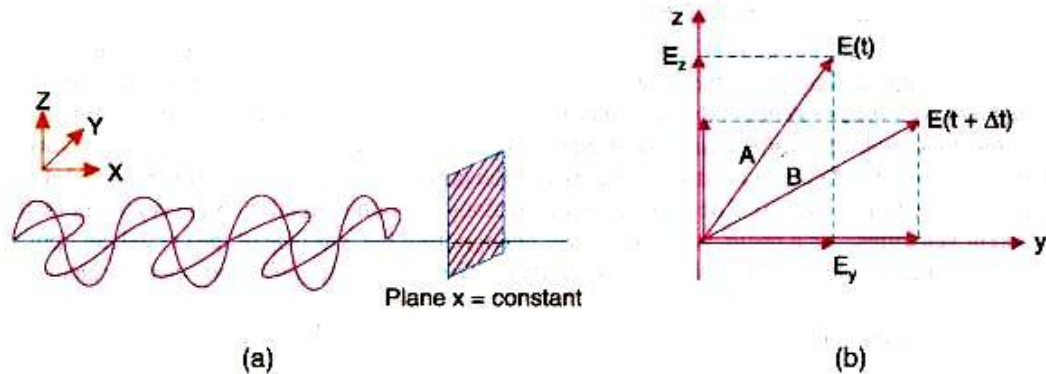

Let, these two waves are represented by the following ways;

$$E_y = E_1 \cos(kx - \omega t) \quad (1)$$

$$E_z = E_2 \cos(kx - \omega t + \delta) \quad (2)$$

Where,  $\delta$  = is phase difference between two waves

$$v = \omega/2\pi = \text{frequency}$$

According to the principle of superposition,

$$E = E_y + E_z = E_1 \cos(kx - \omega t) + E_2 \cos(kx - \omega t + \delta) \quad (3)$$

From equation- (2),

$$\begin{aligned} E_z &= E_2 \cos(kx - \omega t) \cdot \cos \delta - E_2 \sin(kx - \omega t + \delta) \cdot \sin \delta \quad (4) \\ &= E_2 \cos(kx - \omega t) \cdot \cos \delta \pm [1 - \cos^2(kx - \omega t)]^{1/2} \cdot E_2 \sin \delta \end{aligned}$$

# Superposition of waves linearly polarized at right angles

From equation- (1),  $\cos(kx - \omega t) = \frac{E_y}{E_1}$

$$E_z = E_2 \frac{E_y}{E_1} \cos \delta \pm \sqrt{1 - \frac{E_y^2}{E_1^2}} \cdot E_2 \sin \delta \quad (5)$$

Rearranging above equation,  $\left[ E_z - \frac{E_2}{E_1} E_y \cos \delta \right] = \pm \sqrt{1 - \left( \frac{E_y}{E_1} \right)^2} \cdot E_2 \sin \delta$

Squaring both the sides,  $\left[ E_z^2 + \left( \frac{E_2}{E_1} E_y \right)^2 \cos^2 \delta \right] - \frac{2E_y E_z E_2}{E_1} \cos \delta = E_2^2 \sin^2 \delta - \left( \frac{E_2}{E_1} E_y \right)^2 \sin^2 \delta$

$$E_z^2 + \left( \frac{E_2}{E_1} E_y \right)^2 (\cos^2 \delta + \sin^2 \delta) \cos^2 \delta - \frac{2E_y E_z E_2}{E_1} \cos \delta = E_2^2 \sin^2 \delta$$

$$E_z^2 + \left( \frac{E_2}{E_1} E_y \right)^2 - \frac{2E_y E_z E_2}{E_1} \cos \delta = E_2^2 \sin^2 \delta \quad (6)$$

Dividing both side by  $E_2^2$ ,

$$\left( \frac{E_y}{E_1} \right)^2 + \left( \frac{E_z}{E_2} \right)^2 - \frac{2E_y E_z E_2}{E_1} \cos \delta = \sin^2 \delta \quad (7)$$

Above equation, is the general equation of ellipse, hence, the tip of the resultant vector traces an ellipse in **Y-Z** plane. The ellipse is constrained within a rectangle having sides **2E<sub>1</sub>**, and **2E<sub>2</sub>**.

# Superposition of waves linearly polarized at right angles

## Special cases

1. When  $\delta = 0$  or  $\pm 2m\pi$ , then two waves are in phase.

Therefore,  $\cos \delta = 1$  and  $\sin \delta = 0$

Then, equation (4) becomes,

$$\left(\frac{E_y}{E_1}\right)^2 + \left(\frac{E_z}{E_2}\right)^2 - \frac{2E_y E_z E_2}{E_1} = 0 \Rightarrow \left[\frac{E_y}{E_1} - \frac{E_z}{E_2}\right]^2 = 0 \Rightarrow \frac{E_y}{E_1} - \frac{E_z}{E_2} = 0$$
$$\therefore E_z = \frac{E_2 E_y}{E_1} \quad (8)$$

The above equation represents a straight line, having a slope ( $E_2/E_1$ ). It means that, the resultant of two plane-polarized waves is again a plane-polarized wave.

2. When  $\delta = \pi$  or  $\pm (2m\pi + 1)\pi$

The two waves are in opposite phase.

Therefore,  $\cos \delta = -1$  and  $\sin \delta = 0$

Then, equation (4) reduced to,

$$\left(\frac{E_y}{E_1}\right)^2 + \left(\frac{E_z}{E_2}\right)^2 - \frac{2E_y E_z E_2}{E_1} = 0 \Rightarrow \left[\frac{E_y}{E_1} + \frac{E_z}{E_2}\right]^2 = 0 \Rightarrow \frac{E_y}{E_1} + \frac{E_z}{E_2} = 0$$
$$\therefore E_z = -\frac{E_2 E_y}{E_1} \quad (9)$$

This equation represents a straight line of a slope ( $-E_2/E_1$ ). It means that the resultant of two plane polarized waves, which are in opposite phase, is against a plane-polarized wave.

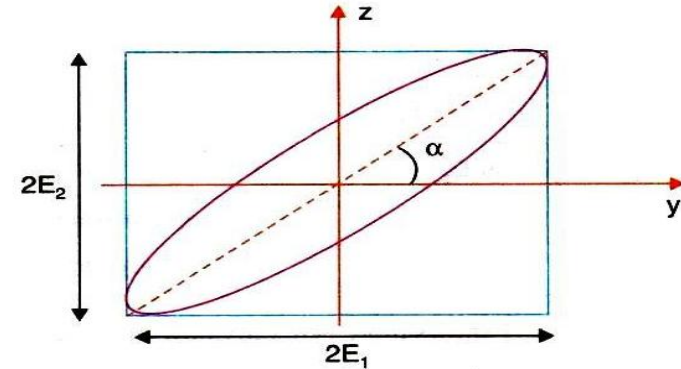

# Superposition of waves linearly polarized at right angles

3. If  $\delta = \pi/2$  or  $\pm (2m\pi + 1) \pi/2$

$$\cos \delta = 0 \text{ and } \sin \delta = 1$$

Then, equation (4) reduced to,  $\frac{E_y}{E_1} + \frac{E_z}{E_2} = 1$  (10)

This is the equation of ellipse. Its major and minor axis considers with y-and z coordinates axes. Thus the waves are out of phase by  $90^\circ$  and their resultant wave is elliptically polarized wave.

4. If  $\delta = \frac{\pi}{2}$  and  $E_1 = E_2 = E_0$

Then, equation (4) reduced to,  $E_1^2 + E_2^2 = E_0^2$

This is the equation of circle. Hence result wave is circularly polarized.

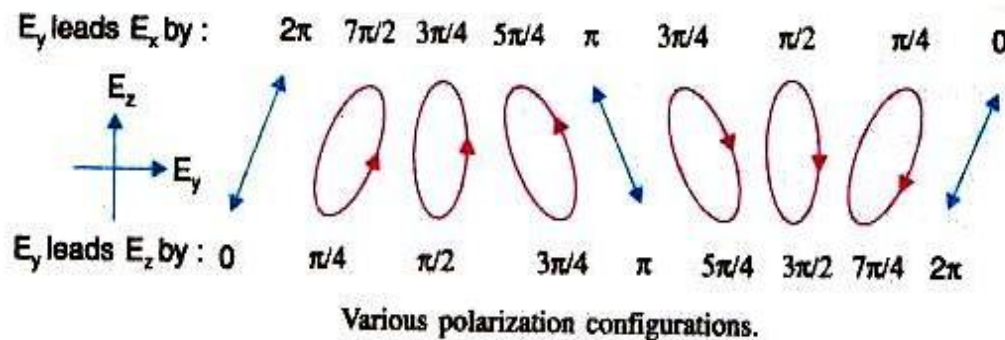

# RETARDERS

A retarder is a uniform plate of birefringent material whose optic axis lies in the plane of the plate. Retarders are called Quarter-wave plates, Half-wave plates and full-wave plates depending on their action. They divide the incident wave into two polarized waves that travel perpendicular to the plate at different speeds. *A phase retardation of one wave relative to the other is therefore introduced as the wave cross the thickness  $d$  of the plate. They are used to produce circularly or elliptically polarized light and to analyze polarized light into elliptical components.*

## QUARTER WAVE PLATE

A quarter wave plate is a thin plate of birefringent crystal having the optic axis parallel to its refracting faces and its thickness chosen such that it introduces a quarter-wave ( $\lambda/4$ ) path difference (or a phase difference of  $90^\circ$ ) between e-ray and o-ray. When a plane polarized light wave is incident on a birefringent crystal having the optic axis parallel to its refracting faces, the wave splits into o-wave and e-waves as shown in **fig**. The two waves travel along the same direction inside the crystal but with different velocities. As a result they emerge from the rear face of the crystal, an optical path difference would be developed between them. Thus,

$$\therefore (\mu_o - \mu_e)d = \frac{\lambda}{4} \quad \Rightarrow \quad \therefore d = \frac{\lambda}{4(\mu_o - \mu_e)}$$

A quarter-wave plate introduces a phase difference  $\delta$  between e-ray and o-ray given by  $\delta = (2\pi/\lambda)\Delta = \pi/2 = 90^\circ$ .

A quarter-wave plate is used for producing elliptically or circularly polarized light. It converts plane polarized light into elliptically or circularly polarized light depending upon the angle that the incident light vector makes with the optic axis of the quarter wave plate.

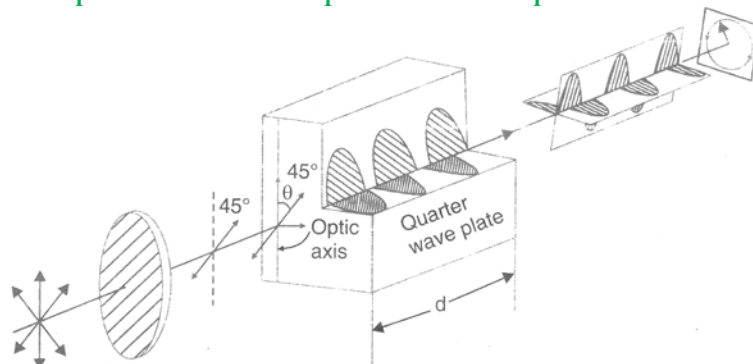

# HALF WAVE PLATE

A half wave plate is a thin plate of birefringent crystal having the optic axis parallel to its refracting faces and its thickness chosen such that it introduces a half wave ( $\lambda/2$ ) path difference (or a phase difference of  $180^\circ$ ) between e-ray and o-ray.

When a plane polarized light wave is incident on a birefringent crystal having the optic axis parallel to its refracting faces, it splits into two waves : o-and e-waves. The two waves travel along the same direction inside the crystal but with different velocities. As a result, when they emerge from the rear face of the crystal, an optical path difference would be developed between them

$$\therefore (\mu_o - \mu_e)d = \frac{\lambda}{2} \quad \Rightarrow \quad \therefore d = \frac{\lambda}{2(\mu_o - \mu_e)}$$

A half wave plate introduces a phase difference  $\delta$ , between e-ray and o-ray given by  $\delta = (2\pi/\lambda)\Delta = \pi = 180^\circ$

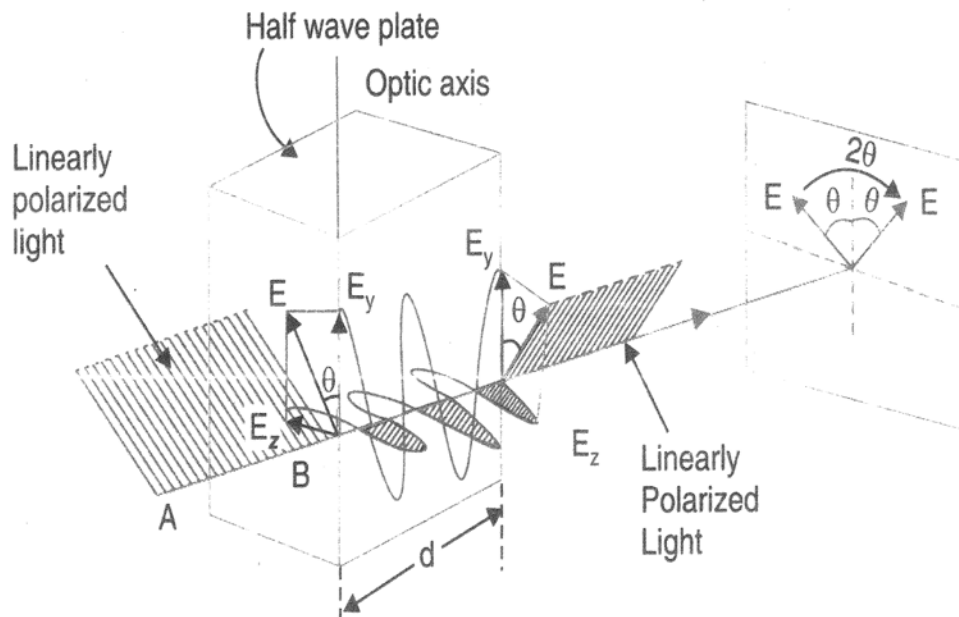



## HALF WAVE PLATE

Now let a plane polarized light be incident normally on half wave plate. Let the electric vector  $E$  make an angle with the optic axis of the half wave plate (see **fig.**). The incident wave splits into two waves, e-and o-waves. The waves progressively develop path difference as they travel through the crystal and they emerge with a phase difference of  $180^\circ$ . When the two waves combine, they yield a plane polarized wave, which has its plane of polarization rotated through an angle of  $2\theta$ .

Therefore, a half wave plate rotates the plane of polarization of the incident plane polarized light through an angle  $2\theta$ . The half wave plate will invert the handedness of elliptical or circular polarized light, changing right to left and vice versa.

Now we are in a position to understand what happens when e-ray and o-ray overlap on each other after emerging from an anisotropic crystal plate. It is obvious that they cannot produce interference fringes as in a double slit experiment. On the other hand, they combine to produce different states of polarization depending upon their optical path difference.

1. When the optical path difference is 0 or an even or odd multiple of  $\lambda/2$ , the resultant light wave is linearly polarized.
2. When the optical path difference is  $\lambda/4$ , the resultant light wave is elliptically polarized.
3. In the particular instance when the wave amplitudes are equal and the optical path difference is  $\lambda/4$ , the resultant light wave is circularly polarized.

# PRODUCTION OF ELLIPTICALLY POLARISED LIGHT

A quarter wave plate and a polarizer are the optical devices necessary to produce elliptically polarized light from unpolarised light. Unpolarised light is first converted to plane polarized light by allowing it to pass through a polarizer (a Polaroid sheet or a Nicol Prism) as shown in **fig.** . The plane polarized light is then made incident on a quarter wave plate. The quarter wave plate or the polarizer is rotated such that the electric vector  $E$  of plane polarized light wave makes an angle  $\theta$  ( $\neq 45^\circ$ ) with the optic axis of the quarter wave plate. The incident ray divides into o-ray and e-ray of amplitudes  $E\sin\theta$  and  $E\cos\theta$ . The rays travel along the same direction in the crystal with different velocities. The two rays are polarized in orthogonal planes. They are in phase at the front face but progressively get out of phase as they travel through the crystal. When they emerge out of the crystal they will have a path difference of  $\lambda/4$  or a phase difference of  $90^\circ$ . When they continue, they produce elliptically polarized light.

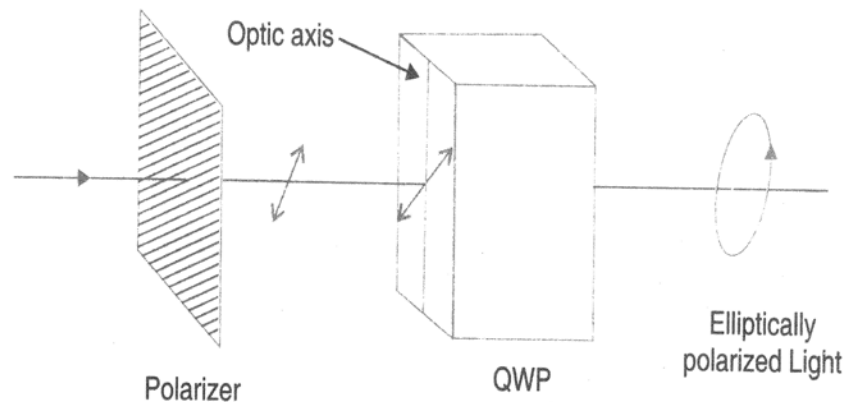

## DETECTION OF ELLIPTICALLY POLARIZED LIGHT

The light beam is allowed to pass through an analyzer (a polarized sheet or a Nicol Prism). If on rotating the analyzing Polaroid sheet or Nicol prism, the intensity of the emerging beam varies from a maximum to a minimum value, but never reaching zero, then the incident light is **elliptically polarized**.

A similar result would be obtained if the incident light were partially polarized. The two cases may be distinguished by inserting a quarter wave plate in the path of light before it falls on the analyzer. If the original light is elliptically polarized it may be considered as resultant of two coherent plane polarized waves that is e-ray and o-ray, which are out of phase by  $90^\circ$ . If the light passes through the quarter wave plate, an additional phase difference of  $90^\circ$  is introduced between the e-ray and o-ray. Therefore the total phase difference becomes  $180^\circ$  between the e-ray and o-ray. On emerging from the quarter plate, the e-and o-rays combine to produce plane polarized light. If the light coming out of quarter wave plate is examined with an analyzer, light will be extinguished twice in one full rotation of the polarizer as shown in **fig.**

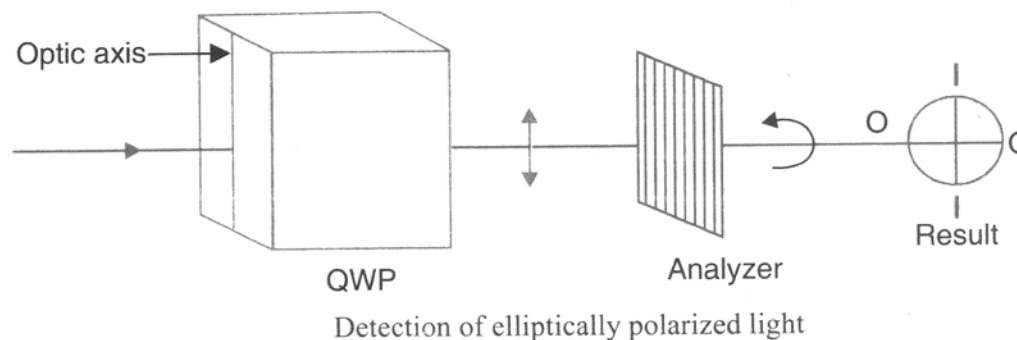

# PRODUCTION OF CIRCULARLY POLARISED LIGHT

A quarter wave plate and a polarizer are the optical devices required for producing circularly polarized light from unpolarised light. Unpolarised light is first converted to plane polarized light by allowing it to pass through a polarizer (a Polaroid sheet or a Nicol Prism), as shown in **fig.** . Plane polarized light is then made incident on a quarter wave plate. The polarizer and the quarter wave plate are rotated such that the electric vector  $E$  of the plane polarized wave makes an angle of  $45^\circ$  with the optic axis of the quarter wave plate. The plane polarized wave incident on the quarter wave plate splits into two rays, o-ray and e-ray of equal amplitude ( $E_1 \cos 45^\circ = E_2 \sin 45^\circ$ ). The two rays travel in the same direction inside the crystal but with different velocities. The two rays are in phase at the front face of the crystal but progressively get out of phase as they travel through the crystal. As they emerge from the rear of the crystals, they will have a path difference  $\lambda/4$  or phase difference of  $90^\circ$ . The two rays are linearly polarized in mutually perpendicular directions. **When they combine they produce *circularly polarized light*.**

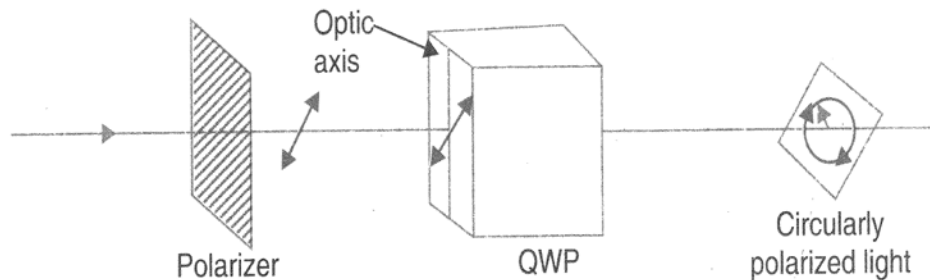

Production of Circularly Polarized Light

# DETECTION OF CIRCULARLY POLARISED LIGHT

The light beam is allowed to pass through an analyzer (a Polaroid sheet or a Nicol prism). If on rotating the analyzing Polaroid sheet or Nicol prism, the intensity of the emerging beam remains uniform, then the incident light is *circularly polarized*. A similar result would be obtained if the incident light is ordinary unpolarised light. The two cases may be distinguished by inserting a quarter wave plate in the path of light before it falls on the analyzer. If the original light is circularly polarized, it may be considered as resultant of two coherent plane polarized waves that is e-ray and o-ray, which are out of phase by  $90^\circ$ . If the light passes through the quarter wave plate, an additional phase difference of  $90^\circ$  is introduced between the e-ray and o-ray. Therefore the total phase difference becomes  $180^\circ$  between the e-ray and o-ray. On emerging from the quarter plate, the e-and o-rays combine to produce plane polarized light. Therefore, if the light coming out of quarter wave plate is examined with an analyzer, light will be extinguished twice in one full rotation of the polarizer as shown in **fig.** or otherwise the incident light is unpolarised.

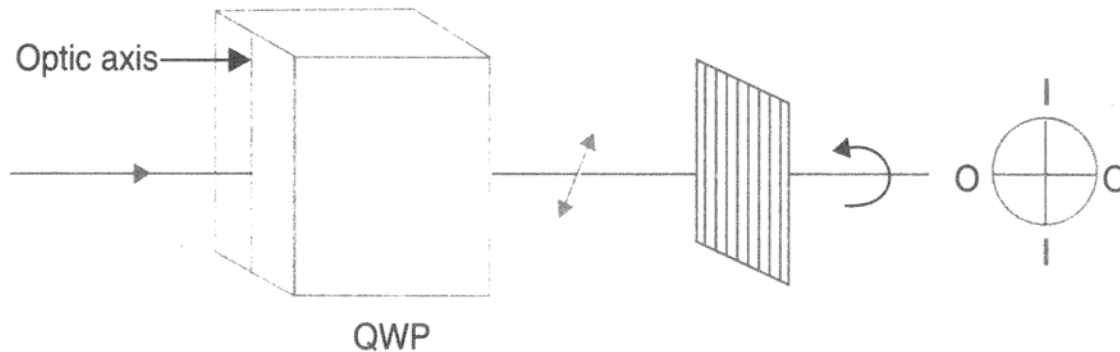

Detection of circularly polarized light

# ANALYSIS OF POLARIZED LIGHT

In practice light may exhibit any one of the three types of polarization, or may be unpolarised or a mixed type. The unaided eye cannot distinguish the different types of polarization. However, using a polarizer and a quarter wave plate, the actual type of polarization of a light beam can be ascertained. The following steps are used in the analysis of the type of polarization.

The light of unknown polarization is allowed to fall normally on a polarizer. The polarizer is slowly rotated through a full circle and the intensity of the transmitted light is observed. If the intensity of the transmitted light is extinguished twice in one full rotation of the polarizer, then the incident light is **plane polarized**.

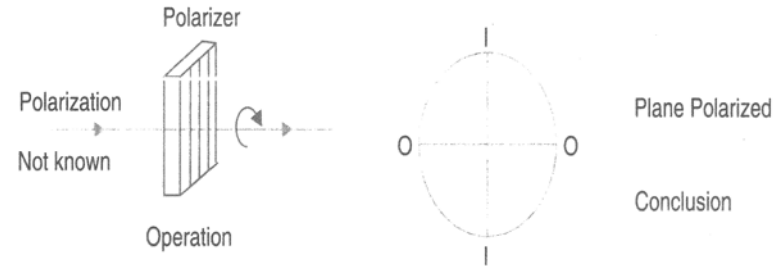

i) If the intensity of the transmitted light varies between a maximum and a minimum value but does not become extinguished in any position of the polarizer, then the incident light is either elliptically polarized or partially polarized.

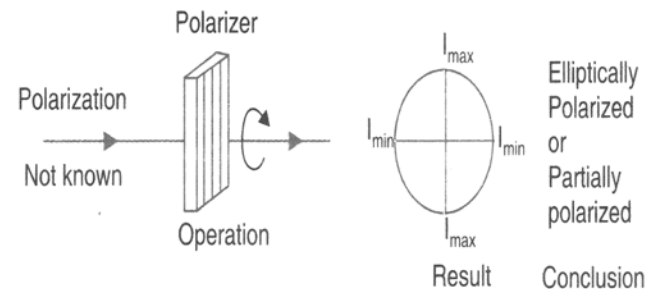

# ANALYSIS OF POLARIZED LIGHT

ii) If the intensity of the transmitted light remains constant or rotation of the polarizer, then the incident light is either **circularly polarized or unpolarised**. To distinguish between elliptically polarized and partially polarized or between the circularly polarized and unpolarised light, we take the help of quarter wave plate. The light is first made to be incident on the quarter wave plate and then it passes through the polarizer.

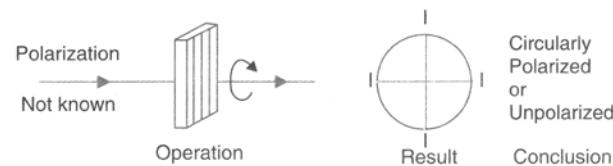

iii) If the incident light is elliptically polarized, the quarter wave plate converts it into a plane polarized beam. When this polarized light passes through the polarizer, it would be extinguished twice in one full rotation of the polarizer.

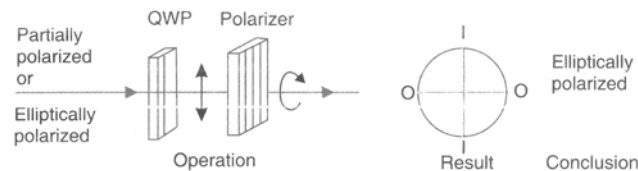

On the other hand, if the transmitted light intensity varies between a maximum and a minimum without becoming zero, then the incident light is **partially polarized**.

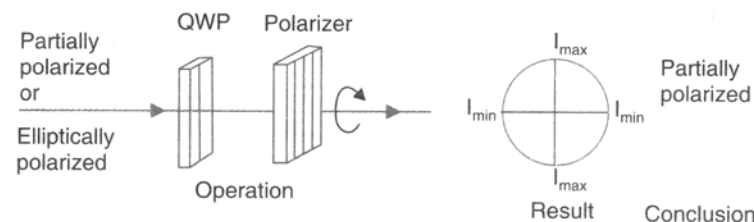

# ANALYSIS OF POLARIZED LIGHT

iv) If the incident light is circularly polarized, the quarter wave plate converts it into plane polarized light. When the plane polarized light passes through the polarizer, it would be completely extinguished twice in one full rotation of the polarizer.

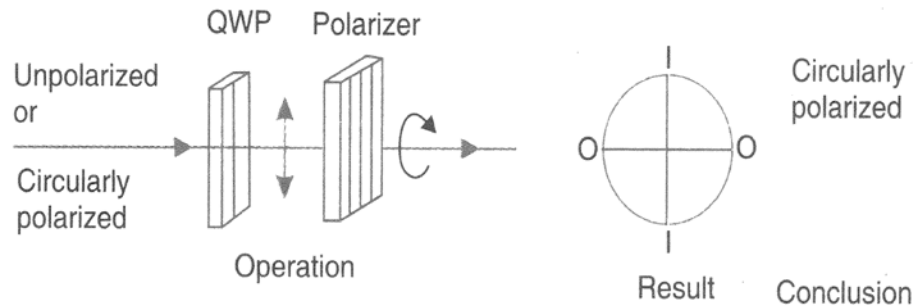

On the other hand, if the intensity of the transmitted light stays constant, then the incident light is unpolarised.

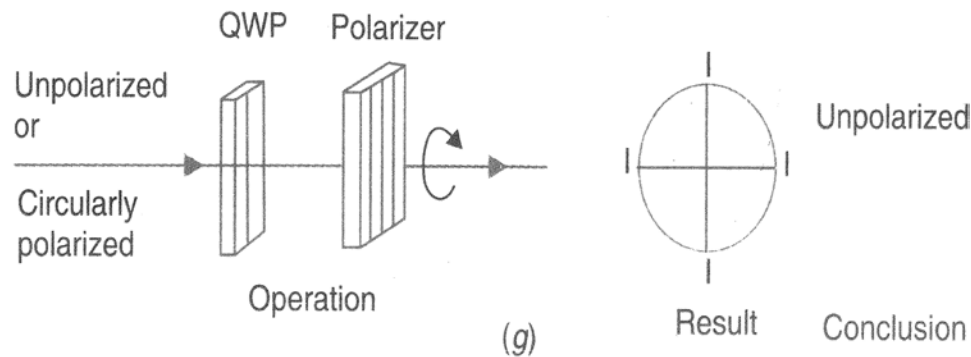



# BABINET COMPENSATOR

A compensator is an optical device whose function is to compensate a path difference. It is used in conjunction with a polarizer and analyzer combination to investigate elliptically polarized light. The compensator helps in determining the axis of the ellipse and the ratio of their lengths. Elliptically polarized light may be considered as the resultant of two coherent plane polarized vibration occurring in mutually orthogonal directions and with an initial path difference of  $\lambda/4$ . When the elliptically polarized light passes through the device such that it introduces a further path difference of  $\lambda/4$ . The total path difference between the perpendicular vibrations becomes  $\lambda/2$  and the vibrations recombine after emerging from the device to produce plane polarized light. From the analysis of this plane polarized light, the information regarding the incident elliptically polarized light can be obtained.

## CONSTRUCTION

The Babinet compensator is made of two wedge shaped quartz sections, ABC and ADC, having equal acute angles. The wedges are placed against each other such that they form a small rectangular block as shown in **fig.** One of the quartz wedges is fixed and the other can be displaced along their plane of contact with the help of a micrometer screw arrangement. Thus, the combination acts as a plate of variable thickness.

The optic axis of the first section is parallel to its refracting edge AB and the optic axis of the second section is in a direction perpendicular to the edge. The two optic axes are perpendicular to each other and also perpendicular to the incident beam.

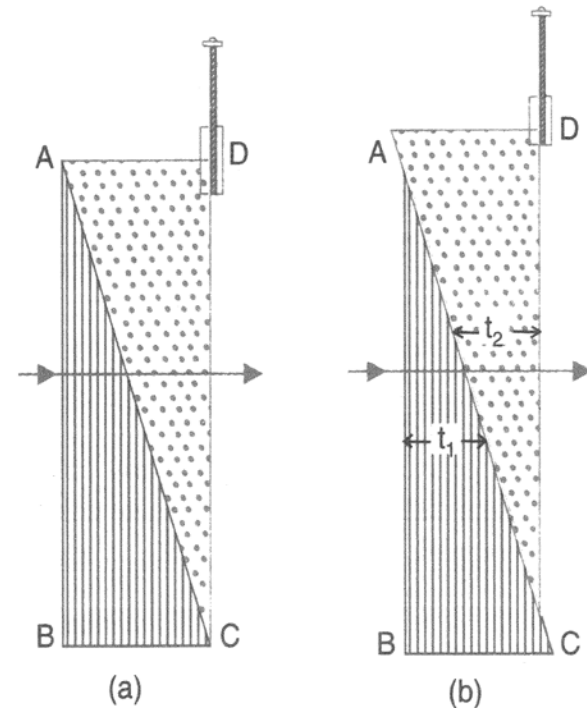

# PRODUCTION OF POLARISED LIGHT

Let plane polarized light be incident normally on the face AB of the compensator. It splits into e-ray and o-ray parallel and perpendicular to AB respectively. The e-ray travels slower than o-ray in the first section, since quartz is a positive uniaxial crystal. When these rays enter the second section, the e-ray becomes o-ray since the optic axis in the second section is in a direction normal to that in the first prism. Similarly, o-ray becomes e-ray. Thus, the two rays exchange their velocities in passing from one section to the other section. The net effect is that one section cancels the effect of the other.

If  $d_1$  is the thickness of the first section and  $\mu_e$  and  $\mu_o$  are the refractive indices of quartz for e - and o-rays respectively, the path difference between the e- and o- rays in the first section will be

$$\Delta_1 = [\mu_e - \mu_o] d_1$$

As the principal planes of the two sections are at right angles the e- and o- rays change their roles in going from the first section to the second section. The velocities of e-ray and o-ray are interchanges and if the thickness of the second section is  $d_2$ , then the path difference between the rays in the second prism will be

$$\Delta_2 = [\mu_o - \mu_e] d_2$$

As the compensator is thin, the separation of the rays is negligible. The net path difference between the two rays after emerging from the crystal will be

$$\Delta = \Delta_1 + \Delta_2$$

$$\Delta = [\mu_e - \mu_o] d_1 + (\mu_o - \mu_e) d_2 = (\mu_e - \mu_o) (d_1 - d_2)$$

The net phase difference is

$$\delta = \frac{2\pi}{\lambda} (\mu_e - \mu_o) (d_1 - d_2)$$

For a ray passing through the centre of the compensator where  $d_1 = d_2$  the net path difference and hence the phase difference is zero. It means that the effect of one wedge is exactly cancelled by the other. This is true for all wavelengths and the incident vibration is transmitted as such. Plane polarized light incident on the compensator will emerge as plane polarized light with its plane of vibration parallel to that of the incident light.

Any desired thickness difference ( $d_2 - d_1$ ) can be achieved at the Centre of the compensator by moving the second section relative to the first section. Thus, any desired value of phase difference can be obtained between the e and o-rays. Therefore, the light emerging will be either plane or circular or elliptically polarized light, depending on the phase difference.

Thus the compensator has the same effect as that of a wave plate of varying thickness. The advantage of compensator is that it can be arranged to suit any wave length while a quarter wave plate is designed to suit only one particular wave length (say  $\lambda/4$ ).

# ANALYSIS OF ELLIPTICALLY POLARISED LIGHT

Using the compensator, one can determine the characteristics of elliptically polarized light.

Let the compensator be placed between crossed polarizer P and analyzer A, as shown in **fig.** . Let the transmission axis of polarizer be oriented at  $45^\circ$  with respect to the optic axis of wedge ABC of the compensator. At midpoint R the light emergent from the compensator is plane polarized in the same plane as transmitted by P and therefore it will be extinguished by the analyzer A. Similarly at distances from the midpoint for which the retardation is  $1\lambda$ ,  $2\lambda$ ,  $3\lambda$  ..... $m\lambda$  and the emergent light is plane polarized in the same plane as transmitted by P and hence will be extinguished by the analyzer. So the field of view is crossed by a series of equidistant parallel dark bands.

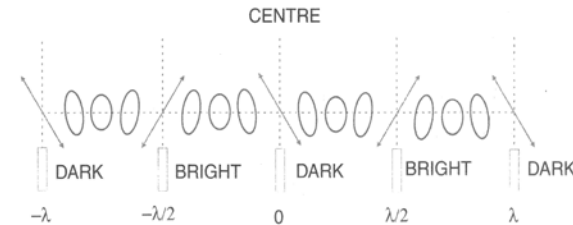
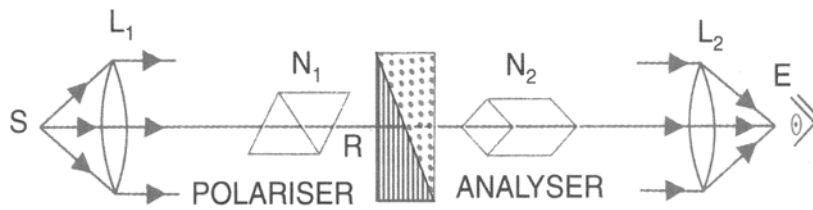

At positions between them where the path difference corresponds to an odd multiple of  $\lambda/2$ , i.e.  $\lambda/2$ ,  $3\lambda/2$ ,  $5\lambda/2$ ...  $(2m + 1)\lambda/2$  the transmitted light is plane polarized. The analyzer transmits the light completely and those regions will be bright. In all other cases, the emerging light is elliptically polarized with varying parameters of the ellipse, as shown in **fig.** . *If white light is used, the central band will be dark while others will be coloured.*

By using white light source, the compensator is adjusted such that the central dark band is under cross wire and the micrometer reading is noted. The micrometer screw is turned through an angle such that the compensator introduces a phase difference of  $\pi/2$  at cross wire. Then elliptically polarized light is made to be incident on the compensator. The central dark band undergoes a shift with respect to the cross wire. The compensator is rotated through an angle  $\alpha$  in its own plane until the central dark band is on the cross wire. The axes of the incident elliptically polarized light are parallel to the optic axes of the wedges of the compensator.

# ANALYSIS OF ELLIPTICALLY POLARISED LIGHT

**Phase Difference:** The elliptical vibration can be regarded as made of two mutually perpendicular linear vibrations, which are having a phase difference  $\delta$ ,  $\delta$  can be determined as follows.

First the compensator is illuminated with white plane polarized light and the micrometer is adjusted to bring the central dark band on the cross wires. The white light is then replaced by elliptically polarized light. The central band shift to a point where the original phase difference  $\delta$  between the two component vibrations of elliptical polarized light is exactly balanced by the phase difference introduced by the compensator. The phase difference is determined by rotating the screw until the central dark band is again on the cross wires. If the rotation is  $\phi$  then

$$\frac{\delta}{2\pi} = \frac{\phi}{\alpha} \text{ or } \delta = \frac{2\pi\phi}{\alpha}$$

**Position of axes :** The position of the major and minor axes of the given elliptical vibration can be found as follows. The compensator is illuminated with white polarized light and the micrometer screw is adjusted to bring the central dark band on the cross-wires. The screw is then turned through an angle  $\alpha/4$  so that the compensator introduces a phase difference of  $90^\circ$ . The central dark band now not on the cross wires. The elliptically polarized light is made incident on the compensator. Then the compensator is rotated in its own plane until the central dark bank again comes on to the cross wires. The axes of the incident light are parallel to the optic axes of the wedges of the compensator.

# ANALYSIS OF ELLIPTICALLY POLARISED LIGHT

## Ratio of the axes :

Referring to the **Fig.** OA and OB represent the optic axes of the two wedges of the compensator. OC is the direction of the principal section of the analyzer. DE is the direction of vibration of light emerging from the compensator at the cross wires. The tangent of the angle  $\theta$  that the principal section of the analyzer makes with the optic axes of the wedge give the ratio of the axes. Thus

$$\tan \theta = \frac{a}{b}$$

Where  $\theta$  can be determined by rotating the analyzer until the bands disappear and the field become *uniformly illuminated*. The angle of rotation  $\theta$ .

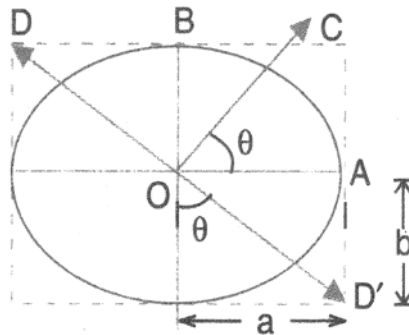

**Advantages:** A quarter wave plate produces a fixed phase difference between o-ray and e-ray and can be used only for monochromatic light of one particular wave length. In case of a compensator, the phase difference between the rays can be varied continuously and hence a compensator, made of a combination of wedges, can be used for light of any given wavelength.

## SPECIFIC ROTATION

A measure of the optically activity of a sample is the rotation produced for a 1 mm slab for a solid, or a 100 mm path length for a liquid. This measure is called the *specific rotation*. Liquids usually rotate the light much less than solids. Solutions of solids will obviously show an effect that depends on the concentration of active material and, to a small extent, both on temperature and the solvent.

If an optically active material is kept between two crossed polarizers, the field of view becomes bright. In order to get darkness once again, the analyzer has to be rotated through an angle  $\theta$ . The angle through which the analyzer is rotated equals the angle through which the plane of polarization is rotated by the optically active substance. This angle depends on

1. The thickness of the substance,
2. Density of the material or concentration of the solution,
3. Wave length of light, and
4. The temperature

The amount of rotation  $\theta$  caused by crystalline materials is given by

$$\theta = \alpha l$$

Where  $\alpha$  is called the *rotational constant*

In solution the amount of rotation  $\theta$  is given by

$$\theta = s c l$$

Where  $c$  is the *concentration* and  $s$  is called the *specific rotation*

*The specific rotation for a given wavelength of light at a given temperature is defined conventionally as the rotation produced by one decimeter long column of the solution containing 1 gm of optically active material per c.c. of solution*

$$[s]_{\lambda}^i = \frac{\theta}{l \times c} = \frac{\text{Rotation in degrees}}{\text{Length in decimetres} \times \text{conc. in gm / c.c}} = \frac{10}{\theta l(\text{cm})c}$$

# LAURENT'S HALF SHADE POLARIMETER

A polarimeter is an instrument used for determining the optical rotation of solutions. When it is used for determining the optical rotation of sugar it is called a *saccharimeter*.

**Construction:** A polarimeter consists of a glass tube for holding the solution under test held between crossed Nicol prisms (**fig.** ). Beyond the polarizing Nicol prism a half-shade plate is located which is used for accurately adjusting the two Nicols for crossed position. Light from a monochromatic source is rendered parallel by the lens L and is incident on the polarizer,  $N_1$ . The light transmitted by the polarizer is plane polarized. The polarized beam then passes through the half-shade plate and as glass tube G containing the solution. The light emerging from the solution will be incident on the analyzer  $N_2$ . The light is observed through a telescope T. The analyzing Nicol  $N_2$  can be rotated about the axis of the tube and the rotation can be measured with the help of a graduated circular scale.

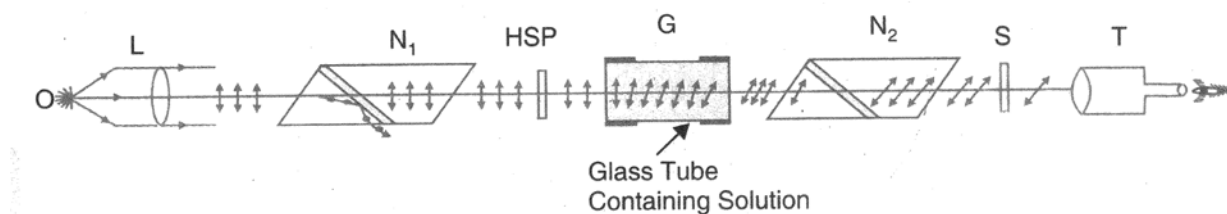

**Working:** To find the specific rotation of a solution, the analyzer is first adjusted such that field of view is completely dark. Then the glass tube is filled with the solution and is held in position. The field of view now becomes illuminated. The field of view can be again made dark by rotating the analyzer through a certain angle which gives the optical rotation of the solution. The practical difficulty in this method is in determination of the exact position for which complete darkness is achieved. The difficulty is overcome by using what is known as a *Laurent's half shade device*.

## LAURENT'S HALF SHADE POLARIMETER

It consists of a semicircular half wave plate ACB of quartz cemented to a semicircular plate ADB of glass (**fig.** ). The optic axis of the wave plate is parallel to the line of separation AB. The half wave plate introduces a phase difference of  $180^\circ$  between e-ray and o-ray passing through it. The thickness of the glass plate such that it transmits the same amount of light as done by the quartz half wave plate. One half of the incident light passes through the quartz plate ACB and the other half through the glass plate ADB. When the light after passing through the polarizer is incident normally on the half shade plate and has vibrations along OP. On passing through the glass, half the vibrations will remain along OP but on passing through the quartz half, the vibrations will split into e- and o-rays. The o-vibrations are along OD and e-vibrations are along OA. The half wave plate introduces a phase difference of  $\pi$  rad between the two vibrations. The vibrations of o-ray will occur along OC instead of OD on emerging from the plate. Therefore the resultant vibration will be along OQ whereas the vibrations of the beam emerging from glass plate will be along OP. In effect, the half wave plate turns the plane of polarization of the incident light through an angle  $2\theta$ .

If the principal plane of the Nicol  $N_2$  is aligned parallel to OP, the plane polarized light emerging from the glass tube will pass through the plate of the half shade plate and that part appears brighter. On the other hand light coming out of the quartz plate is partially obstructed and the corresponding field of view appears less bright. If the principal plane of  $N_2$  is parallel OQ the quartz half will appear brighter than the glass half. Thus, the two halves of the plate are **unequally illuminated**. When the principal plane of  $N_2$  is parallel to AB, the two halves appear **equally bright** and when it is parallel to CD, the two halves are **equally dark**.



# LAURENT'S HALF SHADE POLARIMETER

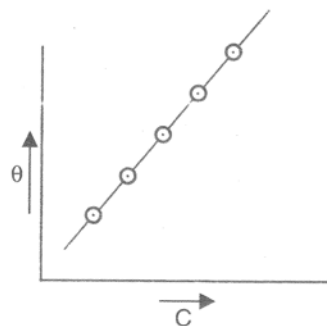
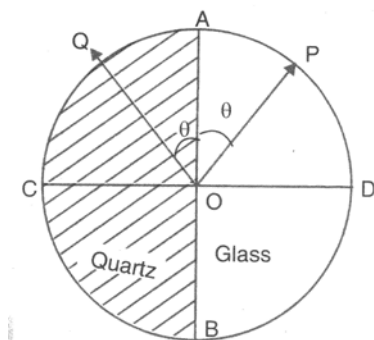

To find the specific rotation of a solution, the analyzer is first in the position for equal darkness without solution in the tube G. The reading on the circular scale is noted. Next, the tube is filled with the optically active solution of known concentration. The field of view is now partially illuminated. The analyzer is rotated till the field of view becomes equally dark. The reading on the circular scale is noted again. The difference between the two scale readings gives the angle of rotation of plane of polarization caused by the solution. Knowing the values of  $\theta$ ,  $l$ , and  $c$ , the specific rotation is obtained using the formula. Or otherwise, knowing the value of the specific rotation, the concentration of the solution can be determined with the help of the equation.

$$[\alpha]_{\lambda}^i = \frac{\theta}{l \times c} = \frac{\text{Rotation in degrees}}{\text{Length in decimetres} \times \text{conc. in gm / c.c}} = \frac{10}{\theta l (\text{cm}) c}$$

In the actual experiment, different concentration of solutions are taken and the corresponding angles of rotation are determined. A graph is plotted between concentration  $c$  and the angle of rotation  $\theta$  are determined. A graph is plotted between concentration  $c$  and the angle of rotation  $\theta$ . The graph is a straight line. Using the value of the slope in above equation, the specific rotation of the optically active substance is calculated.

# LIQUID CRYSTAL DISPLAY (LCD)

Liquid crystal Display is most widely used device which makes the use of polarization. It is used in wristwatches, calculators, clocks, electronic instruments, video games etc.

## Construction

- An LCD consists of liquid crystal material of  $10\mu\text{m}$  thickness.
- It is double refracting material.
- This material is supported between thin glass plates.
- The inner surfaces of thin glass are coated with transparent conducting material.
- This conducting material is etched in the form of a digit or character as shown in fig.2.
- The assembly of glass plates with liquid crystal material is sandwiched between two crossed polarizer sheets.

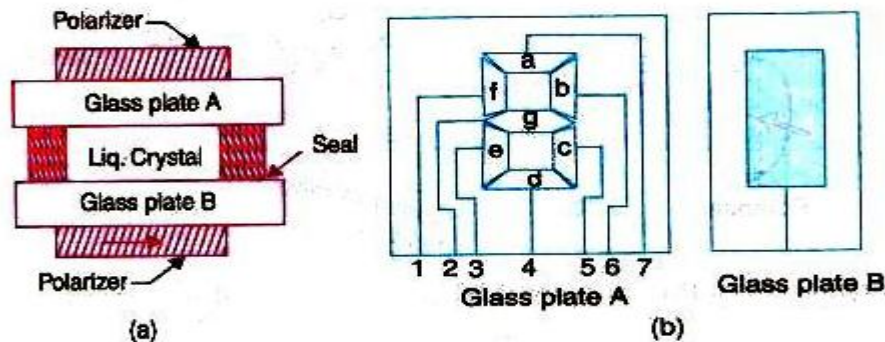

# LIQUID CRYSTAL DISPLAY (LCD)

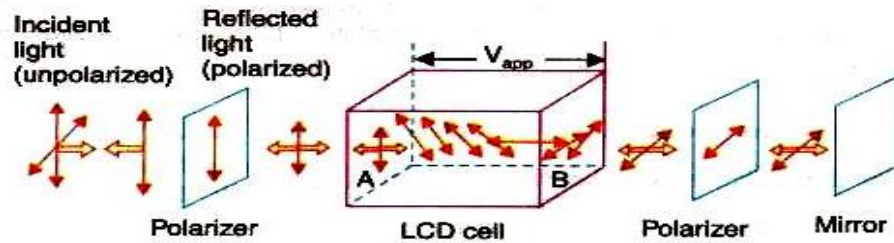

The action of an LCD having a twisted molecular arrangement.

- During fabrication of LCD, the liquid crystal molecules are arranged as shown in fig.3.
- This arrangement of molecules is called twisted molecular arrangement i.e.  $90^\circ$ . Rotation from plate A to B.
- When natural light is incident on the LCD, the front polarizer converts it into linearly polarized light.
- When this polarized light propagates through LCD, the optical vector is rotated by  $90^\circ$  because of twisted molecular arrangement.
- This light passes very easily through the rear polarizer whose transmission axis is perpendicular to that of the front polarizer.
- A reflecting coating at the back of the rear polarizer sends back the light, which comes out from the front polarizer.
- The display seems illuminated uniformly.
- When a voltage is applied to the device, the molecules between the electrodes align along the directions of field.
- When light passes through this region optical vector does not undergo rotation.

The rear polarizer blocks the light and therefore a dark digit or character is seen in that region as shown in figure.